

CCS Technical Documentation

NPD-4 Series Transceivers

Assembly

Assembly Instructions

Note: Use a new part if the antenna has been removed.

1. Antenna assembly.

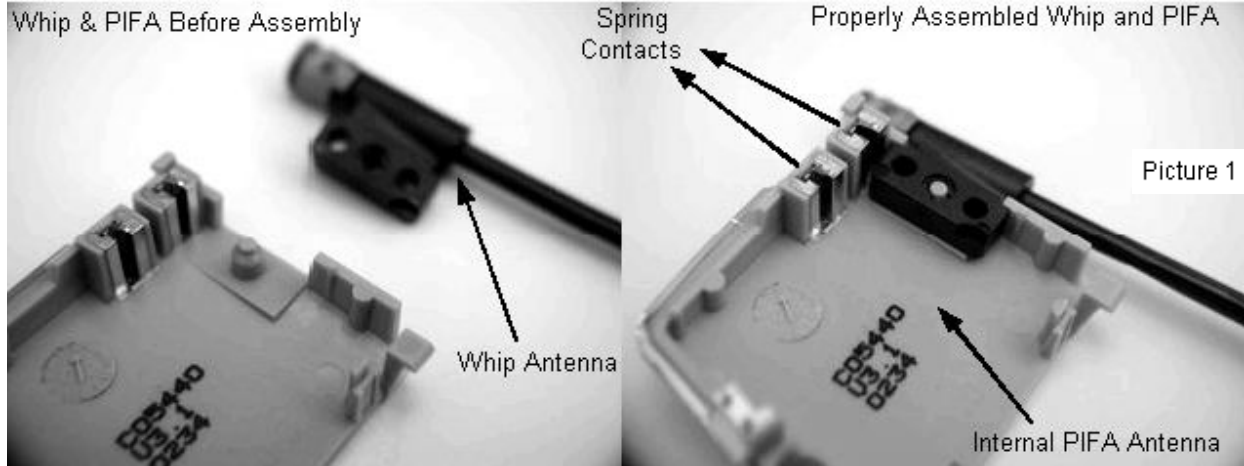

1. Snap whip Antenna onto Internal antenna as shown in the above picture. (Picture 1)

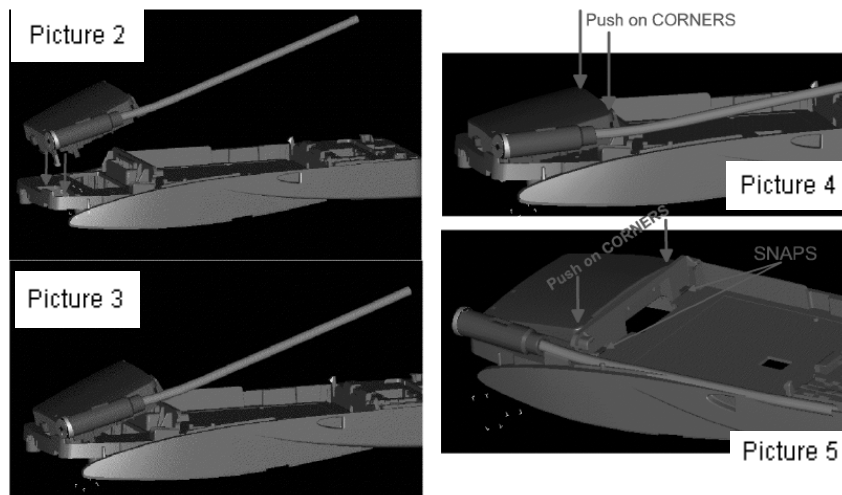

2. Align and insert tip of antenna assembly onto the D cover as shown in Picture 2. *Make sure antenna spring contacts are not bent or broken.*

3. Gently push on the bottom of the antenna assembly and apply a slight amount of forward force – just enough for the antenna snaps to go in. (Shown in Picture 4 above.)

4. Push down on corners of the Antenna and ensure antennas snaps into position as shown in picture 5.



5. Finally, align the whip under the antenna guide and ensure it remains in place without any additional aid. (See picture 6.)

2. Parts assembly.

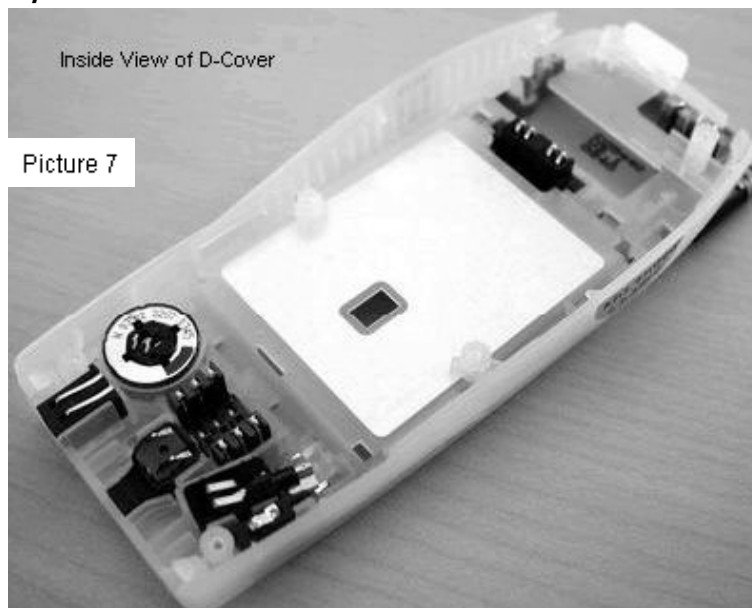

If any of the parts within the D-cover assembly have been removed, insert new parts into their proper locations. The following diagrams (a through i) illustrate in detail the insertion procedures for each assembly part.

a.) Ground clip assembly

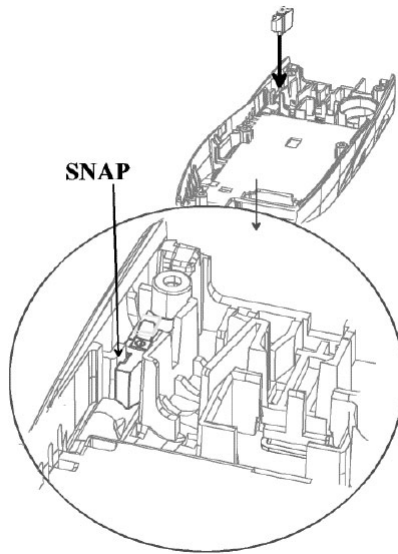

b.) Vibra assembly

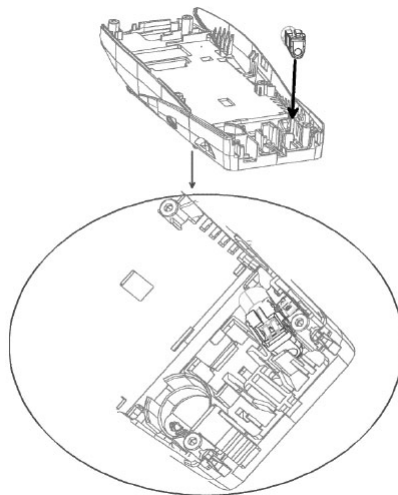

c.) DC jack assembly

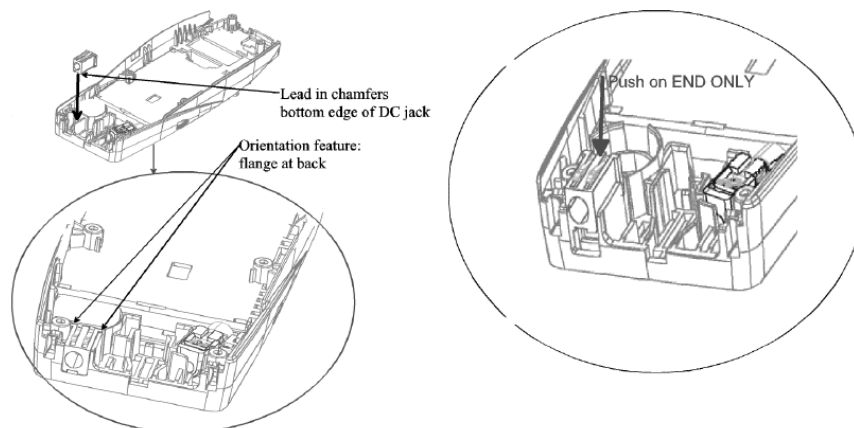

d.) Microphone assembly

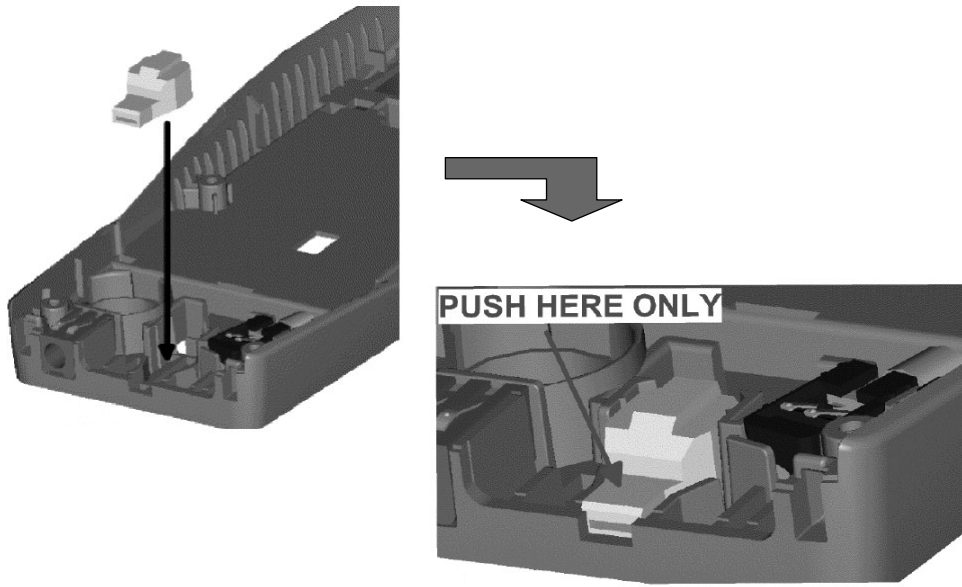

e.) SIM card assembly

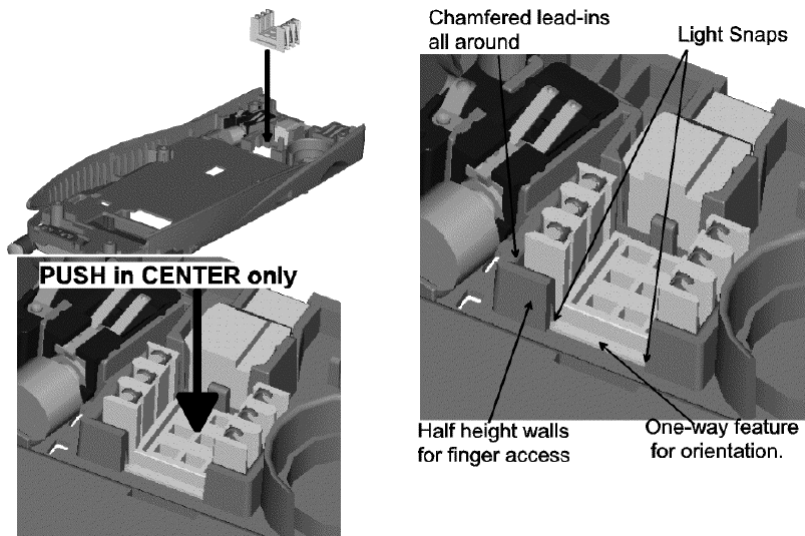

f.) Midi speaker assembly

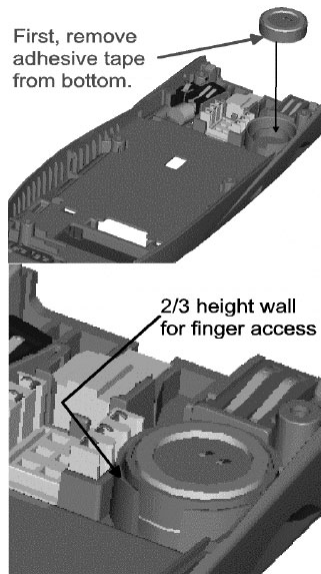

g.) Battery connector assembly

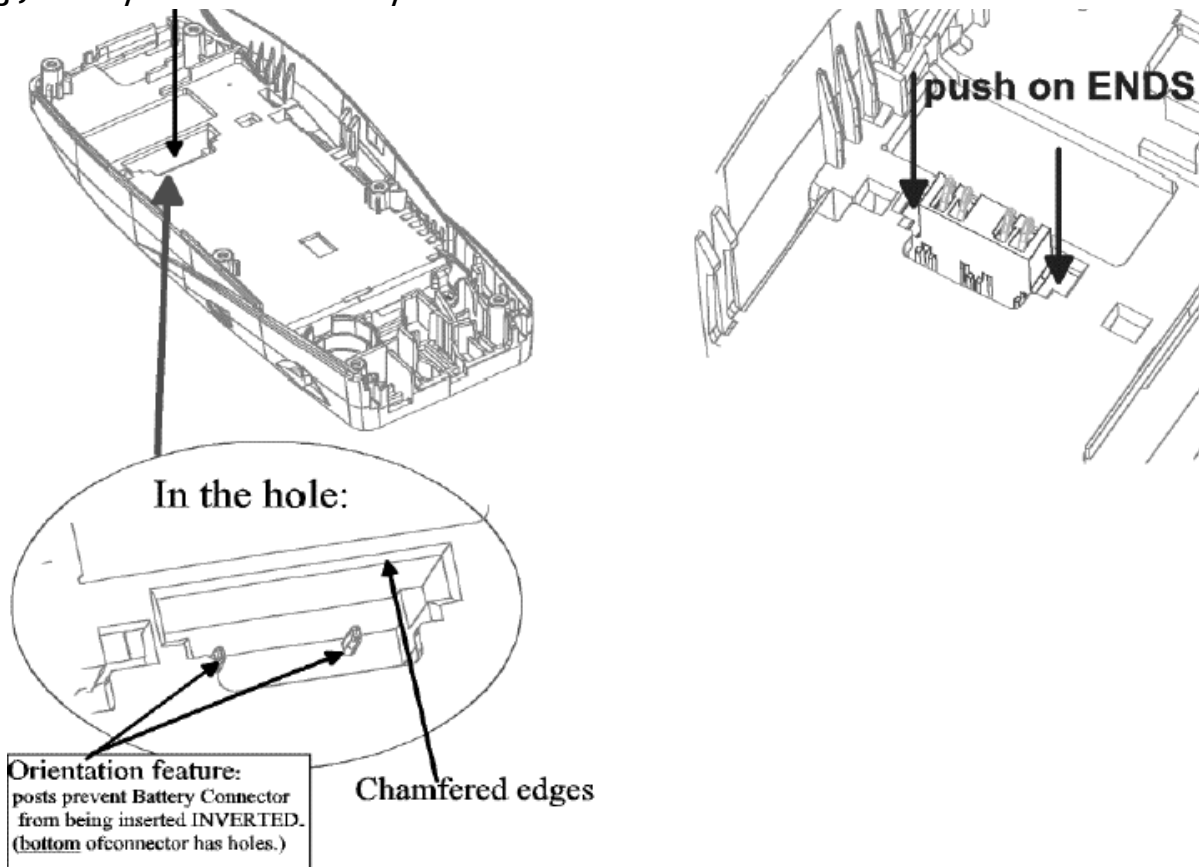

h.) Power button assembly

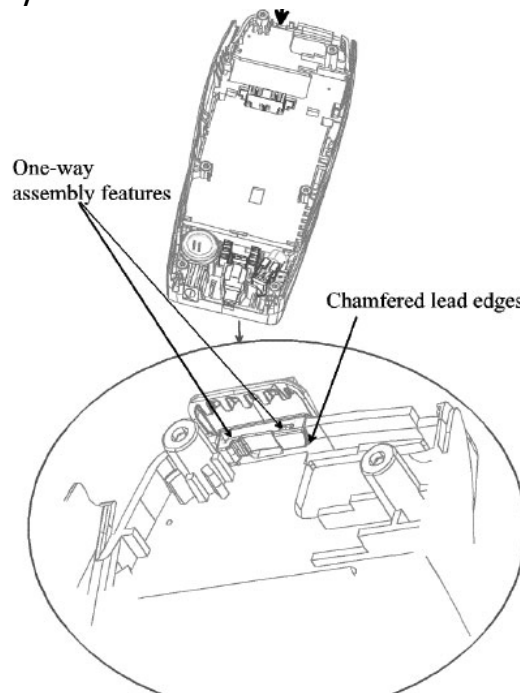

i.) Keymat assembly

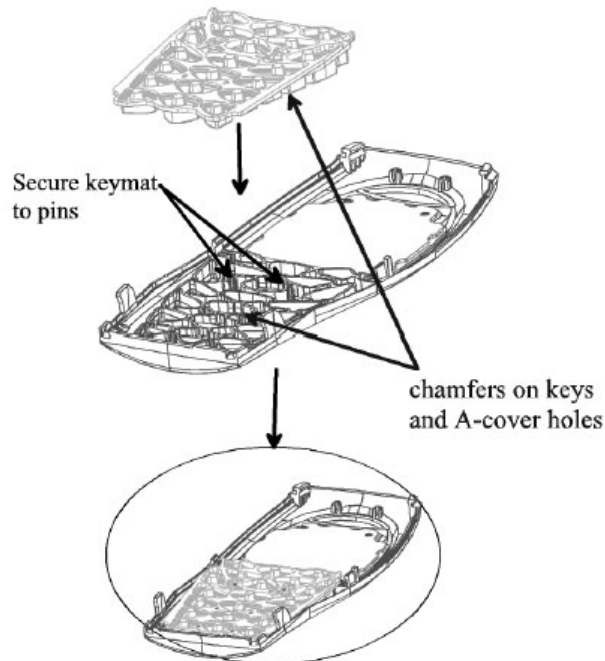

3. PWB assembly.



Place the PWB assembly inside the D-cover, making sure it is correctly aligned.

4. LCD assembly.

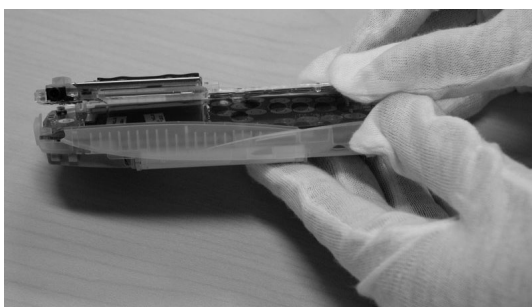

Place the display assembly on top of the PWB inside the D-cover.

Note: Be careful not to bend the display assembly during placement.

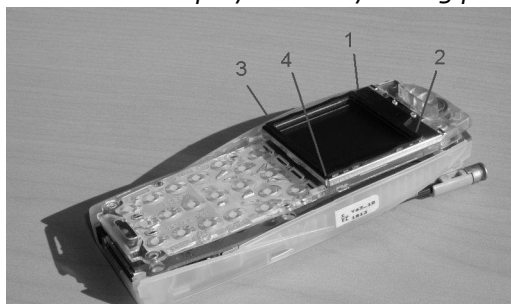

Snap the display assembly into the D-cover in the order shown.

Note: Do not touch or apply pressure directly to the display glass.

5. Screw assembly.

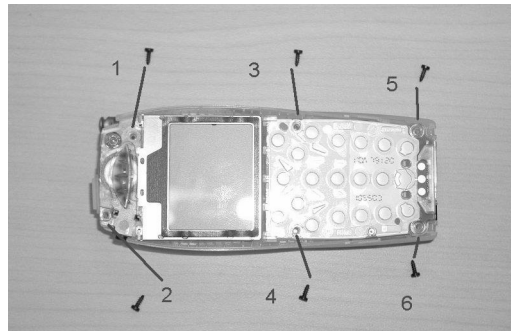

Mount the screws in the order shown above.

Note: Use 23+/-2Ncm (350 RPM max).

Note: Ensure that the display assembly is inserted properly prior to mounting the screws.

6. A-cover assembly.



Mount the A-cover by fitting the guide fins into the D-cover first.

7. B-cover assembly.

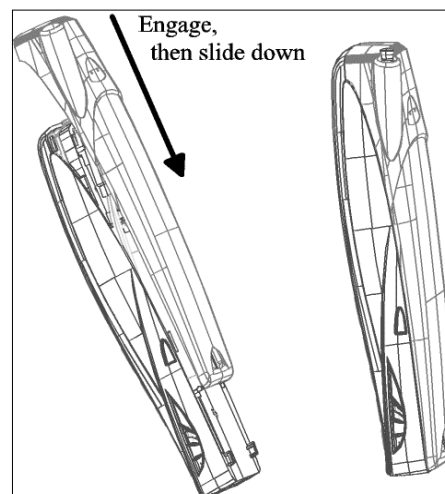

Mount the B-cover as shown.